



Technical Notes on Brick Construction

21B
REVISED

April
2002

Brick Industry Association 11490 Commerce Park Drive, Reston, Virginia 20191

BRICK MASONRY CAVITY WALLS DETAILING

Abstract: This *Technical Notes* contains recommendations for the proper detailing of brick masonry cavity walls. Flashing, weep holes, and sealants are prescribed to control moisture penetration. Bond breaks, adequate bearing details, expansion and movement joints are shown. Seismic detailing is also addressed.

Key Words: bearing, cavity wall, expansion joints, flashing, sealants, parapets, ties.

INTRODUCTION

Materials and workmanship alone are not sufficient to ensure adequate cavity wall performance. Unless properly detailed, cavity walls constructed of the finest materials by the most talented masons will suffer the consequences of poor detailing. This *Technical Notes* promotes quality cavity walls by discussing and depicting pertinent details.

This is the third in a series of *Technical Notes* devoted to brick masonry cavity walls. Other *Technical Notes* in this series discuss cavity walls in general, including; properties, design, material selection, and construction. This *Technical Notes* addresses proper detailing for brick cavity walls.

FLASHING AND WEEP HOLES

Through-wall flashing and weep holes are installed in exterior masonry wall construction to collect and divert moisture that penetrates the exterior wythe of masonry to the outside of the wall. Through-wall flashing must be provided at the base of the wall, at roof and chimney intersections, at roof and wall intersections, and at the top of parapets. Flashing is also needed over and under door and window openings, at shelf angles, and at other horizontal discontinuities in the cavity. Any penetrations in the flashing membrane should be sealed to prevent leakage. Sealants and flashing used together must be compatible so that staining does not occur and long-term performance is maintained.

For flashing and weep holes to perform as intended, the air space separating the masonry wythes must be kept clear of mortar droppings and other obstructions that may bridge the air space. To achieve this end, primary importance should be placed on good workmanship. A secondary method of keeping the cavity clean is through the use of drainage materials specifically

designed to stop any mortar droppings from blocking the cavity and allow water to flow around them. Use of drainage materials is not required, and in some cases may contribute to water penetration problems within the wall. More information on drainage materials is presented in *Technical Notes* 21A of this series.

Drip Edge/Flashing Extension

Water that collects on flashing can re-enter the wall below if flashing terminates behind the face of the wall. For best performance, flashing should be extended $\frac{1}{4}$ in. (6 mm) beyond the wall plane and turned down at an angle of 45 degrees to form a drip. This forces water away from the wall surface.

A protruding flashing is neither possible nor desirable in some cases. For example, exposure to ultraviolet radiation may cause some flexible flashings to deteriorate. In these cases, flashing should be cut flush with the face of the wall. In cases where the flashing itself cannot be exposed, a non-corrosive metal drip edge may be used, see Fig. 1. Before specifying metal drips to be used in conjunction with steel shelf angles or lintels, the poten-

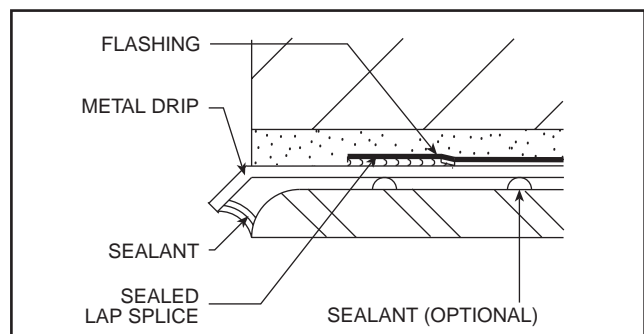

Flashing with Metal Drip Edge
FIG. 1

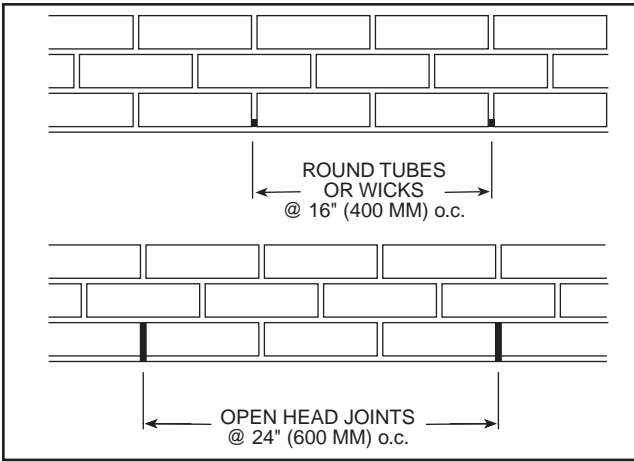

Spacing of Weep Holes
FIG. 2

tial for galvanic action between the metals should be considered. Flashing materials should overlap the metal drip edge by a minimum of 1 in. (25 mm), and be fully bonded to the top surface of the drip edge with a mastic or manufacturer-approved sealant. Metal drip edges should be sealed at all laps and penetrations.

Weep Holes

Weep holes should be placed immediately above all flashing and be spaced no more than 24 in. (600 mm) on center when open head joints are used, and no more than 16 in. (400 mm) on center when wick materials or round tubes are used, see Fig. 2. Open head joints are preferred because they allow water to drain more quickly. Insects do not commonly enter working weep holes, but they can be prevented from entering open head joints by using louvered, vent-type weep inserts, stainless steel wool, or other drainage material.

End Dams

Detailing and installation of end dams cannot be overemphasized. Their purpose is to ensure that collected water is directed toward the weep holes where flashing is not continuous. Such areas occur above windows, doors and other openings and under sills beneath windows. End dams are also used in conjunction with tray flashing at arches, when flashing is stepped, and where a lower sloping roof line intersects a wall. Without end dams the collected water may run off the ends of the flashing into the air space and saturate the brickwork below. To prevent this, each end of the flashing should extend beyond the opening and turn up into the head joint a minimum of 1 in. (25 mm,) or a prefabricated end dam may be used, see Fig. 3.

Foundations

To prevent moisture penetration and promote cavity drainage, place the bottom of the wall so that flashing is above the finished grade. Care should be taken to ensure that flashing and weep holes are placed far enough above grade, typically 8 in. (200 mm), so that they will not be covered by future grading or landscaping, see Fig. 4. With basement construction, it is important to use through-wall flashing at the bottom of the cavity to prevent moisture from penetrating to the basement wall, see Fig. 5. Below the flashing, any cavity should be filled solid with mortar or grout. The flashing also prevents rising damp, ground water drawn up into the brickwork by capillary action. This reduces the potential for staining and efflorescence. The flashing also serves as a bond break between the brick and the concrete foundation. This permits differential movement between the materials and reduces the likelihood of cracking. In construction without basements, the flashing may also serve as a termite shield.

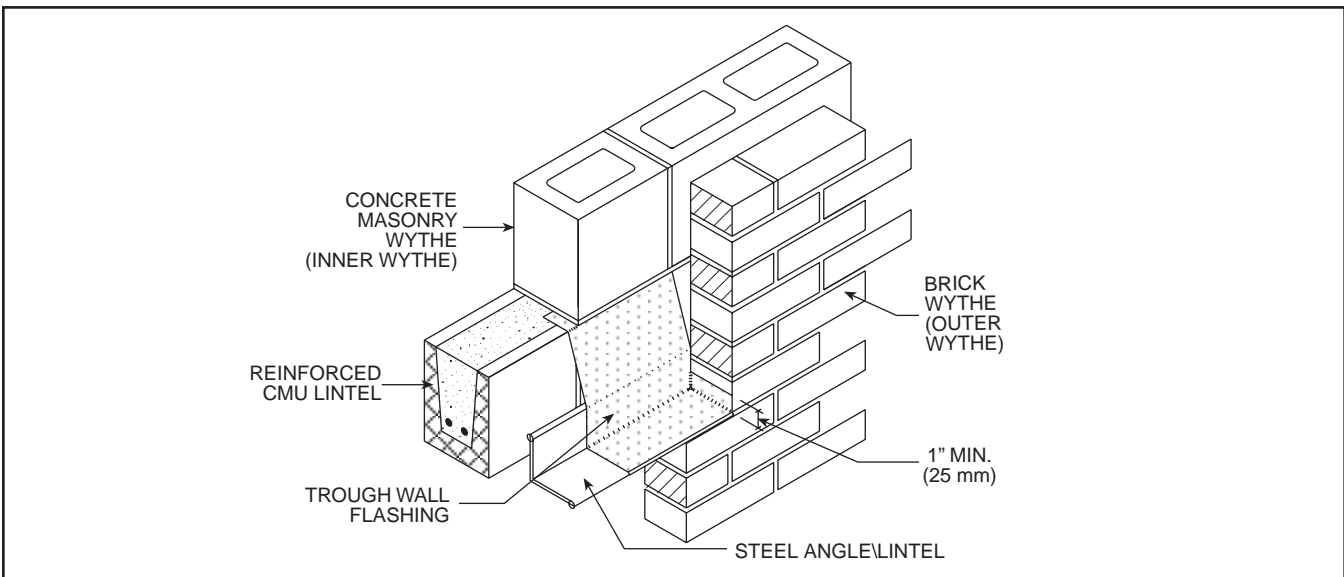

End Dam
FIG. 3

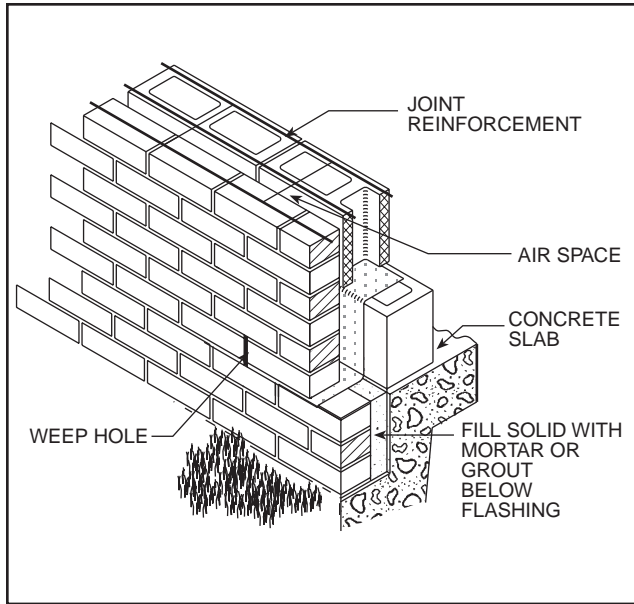

**Foundation Detail
FIG. 4**

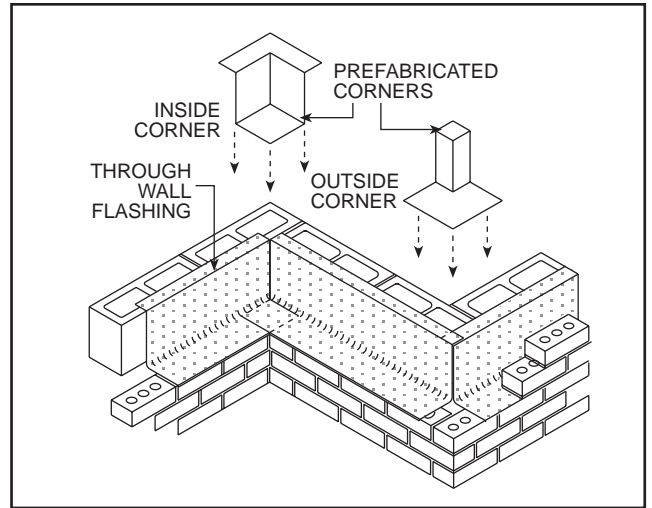

**Prefabricated Corners
(From *Masonry Design and Detailing:
For Architects, Engineers, and Contractors,
4th Edition, Christine Beall*)
FIG. 6**

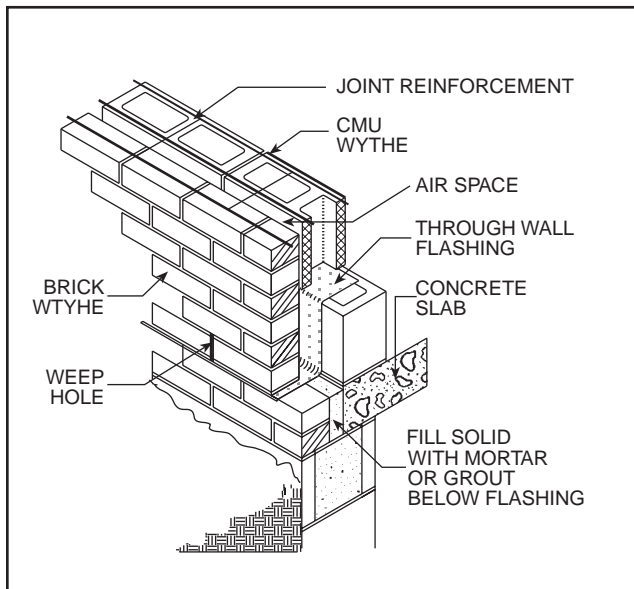

**Basement Detail
FIG. 5**

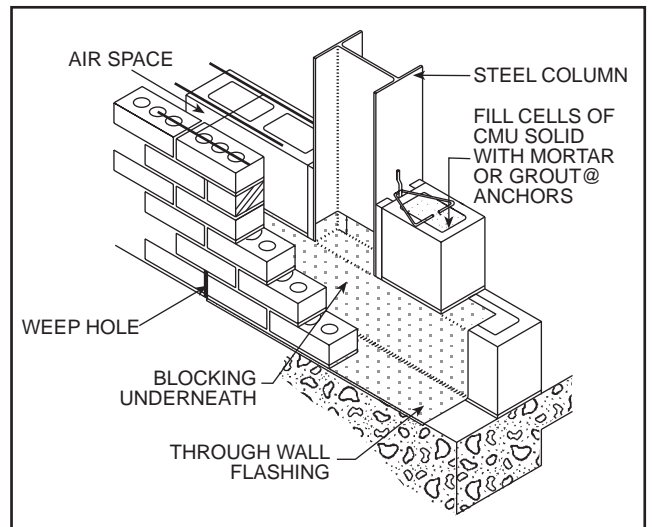

**Flashing at Steel Column
(From *Masonry and Steel Detailing Handbook,
W. Laska*)
FIG. 7**

Corners

It is important to make sure flashing is continuous around corners. Forming corners with conventional flashing is a complicated process involving folding and/or cutting, which increases the potential for flashing failure. Specifying prefabricated corners eliminates the need to cut, patch and fold flashing, thereby reducing some of the potential for water penetration, see Fig. 6. Whether field-formed or prefabricated, all corners should overlap at least 6 in. (150 mm), be sealed with mastic or an adhesive compatible with the flashing material, and conform to the shape of the structure.

Columns

In some cases, vertical supports may make it necessary to cut, puncture or otherwise interrupt the flashing. When this occurs, it is important to make sure that all openings in the flashing are tightly sealed, and that the flashing is attached to these supports with mechanical means or approved adhesives. A common problem condition exists when the inside wythe of a cavity wall spans between steel columns, and the column flanges are perpendicular to the masonry. Fig. 7 illustrates one way that this problem can be addressed. The flashing is formed into a tray and adhered to the column. Cut brick

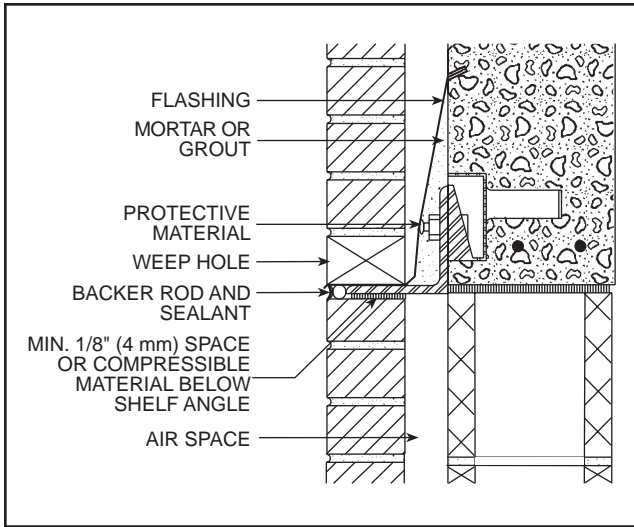

**Shelf Angle Detail
FIG. 8**

or concrete masonry units may be placed at the column base to provide support for the flashing. Otherwise, the flashing can continue in front of the column if it is fully supported from behind.

Shelf Angles

Shelf angles are used to support brick masonry, transfer the weight of brickwork to the structural frame and create horizontal expansion joints. Flashing should be installed over all shelf angles, extended beyond the edge of the angle when possible. Flashing may be self adhered to the shelf angle or have sealant at the edge to prevent wind driven rain from penetrating underneath the flashing. The flashing material should extend back to the inside wythe and turn up a minimum of 8 in. (200 mm). All shelf angles should have a horizontal expansion joint underneath, (see Fig. 8). More information about expansion joints is found later in this *Technical Notes*.

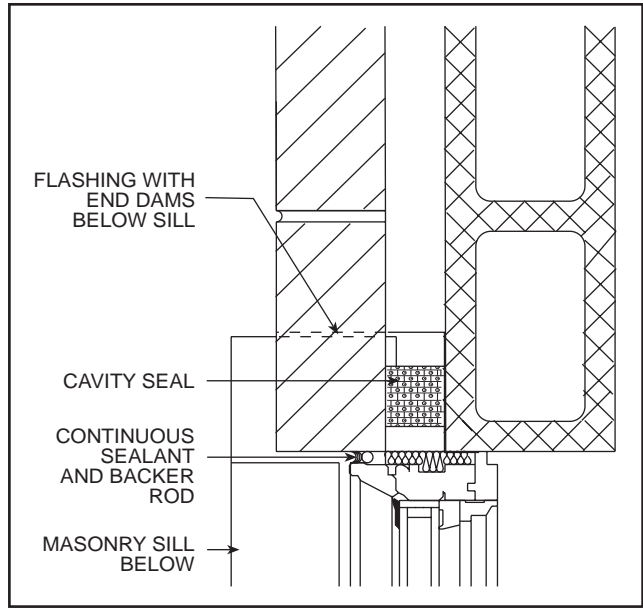

**Window Jamb Detail with Cavity Seal
FIG. 10**

DOORS AND WINDOWS

Detailing openings in masonry cavity walls requires special attention because any air or water which bridges the cavity may cause problems. When the lintel above any masonry opening is not continuous, flashing should extend beyond the ends of the lintel and turn up to form end dams. Air leakage around window and door frames to the cavity can be minimized by placing a pre-compressed pad or sealant in the cavity at the perimeter of the opening. Such a seal is placed at the head of the opening between the back of the lintel and interior masonry wythe, see Fig. 9, and below the window sill. The seal must be integrated with a similar seal at the jamb between the two masonry wythes, see Fig. 10. A sealant joint at the exterior window/masonry interface is

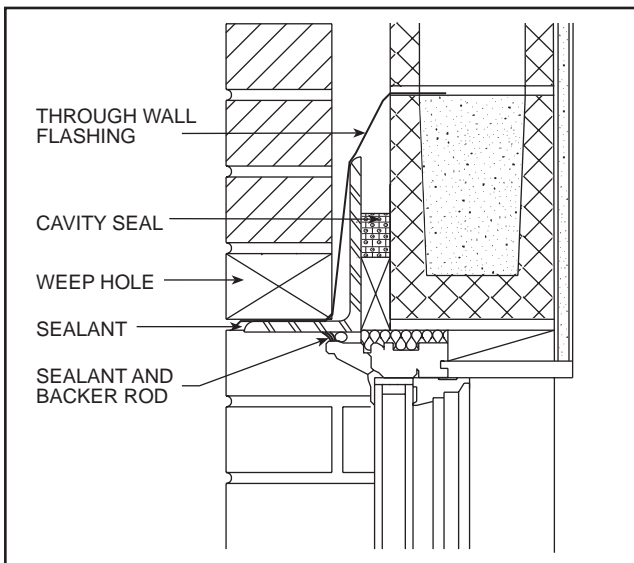

**Window Head Detail and Cavity Seal
FIG. 9**

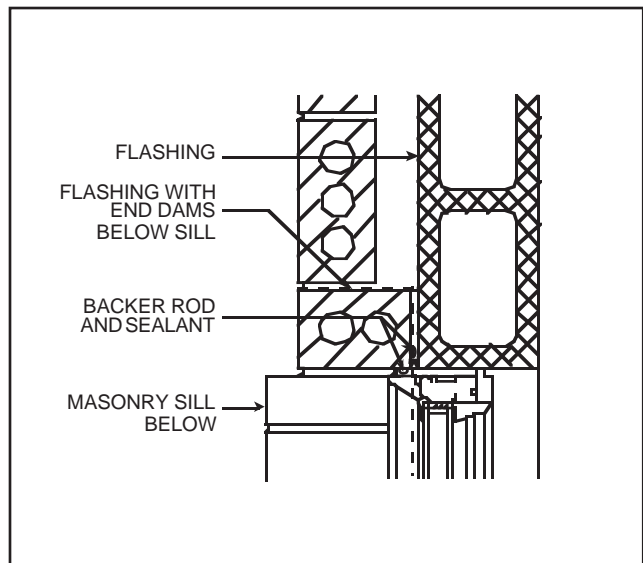

**Window Jamb Detail
FIG. 11**

the primary defense against the ingress of both air and water. Jamb flashing is not required, but may be placed between the interior masonry wythe and the window frame as an additional barrier. In the case of masonry jambs, flashing between the two masonry wythes prevents contact and transmission of water to the interior, see Fig. 11. Jamb flashing should be fully adhered to the interior masonry wythe and extend down to lap over the through-wall flashing at the sill.

Flashing is also needed below window sills, see Figs. 12 and 13. When one-piece continuous masonry sills are specified, the flashing should extend into the exterior masonry wythe at the jambs, see Fig. 10. When detailed in this manner, sill flashing can manage water that bypasses sealant joints at both the sill and jambs. If not so detailed, the jamb flashing must be placed to direct water to the sill flashing. Sealing the pre-compressed cavity seal at the jambs to the sill flashing completes a continuous barrier between the window frame and the cavity. End dams must be formed at the ends of the sill flashing. Self-flashing windows only handle water which makes its way inside the window frame and do not negate the need for the flashing installation described above.

Sealant Joints

Sealant joints are the primary defense against moisture penetration through joints in exterior elements. Sealant joints at masonry openings in exterior walls, such as door and window frames, and expansion joints should be designed, detailed and installed with the same care as other building components, not applied as an afterthought. Too frequently, sealants are used to correct or hide poor workmanship, rather than being included as an integral part of the construction.

Sealants perform best when they are bonded to two opposing surfaces. When a sealant is bonded to three surfaces, its ability to accommodate movement is significantly reduced. Backer rods are recommended and provide support for the sealant within the joint and prevent three-sided adhesion. A bond-breaking tape may be required with some types of backer rods. The sealant should be installed in accordance with the manufacturer’s recommendations. Additionally, maintenance programs should be implemented to inspect and replace sealants that may have dried out, split, or separated from the substrate.

PARAPETS

Of all the masonry elements used in buildings, probably the most difficult to properly detail is a parapet wall. Designers have tried many different ways to minimize cracking, leaking, and displacement. Generally, the only guarantee against parapet problems is to eliminate the parapet. However, they are frequently required by building codes or included for aesthetic reasons.

For cavity wall construction, it is recommended that the cavity continue to the top of the parapet, thereby permitting differential movement between the outer and inner wythes. Expansion joints should extend to the top of the parapet as well. In addition, the inner wythe of the parapet may need to be reinforced and attached to the structural frame. Additional vertical expansion joints should be placed in the parapet, located between those in the wall below, and near corners to avoid displacement of the parapet.

Copings on parapets should provide a drip on at least one side of the wall and slope towards the drip. Metal, stone, and fired clay copings of various designs usually

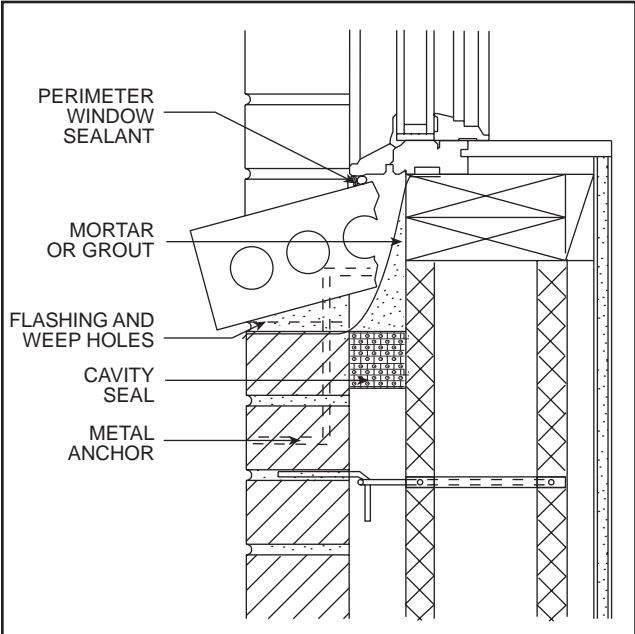

**Window Sill Detail
FIG. 12**

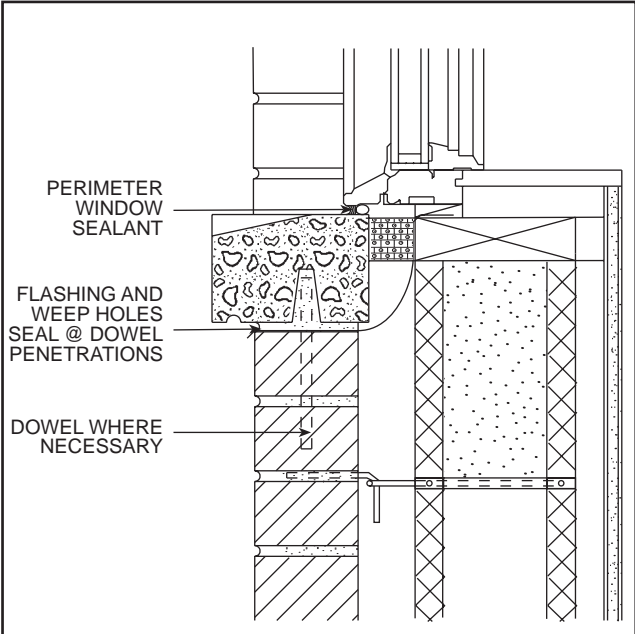

**Window Sill Detail
FIG. 13**

provide this feature. Place through-wall flashing in the mortar joint immediately beneath the coping and firmly attach the coping to the wall below with mechanical anchors. Sealant should be applied where the anchors penetrate the flashing. More information about caps and copings can be found in *Technical Notes 36A*. Parapets should not be painted or coated, they must be able to “breathe”. Roofing membrane should not extend up the back side of the parapet without consideration of moisture vapor transmission.

MOVEMENT JOINTS

Vertical Expansion Joints

The exterior of each building must be analyzed to determine the potential for horizontal movement, and provisions must be made to relieve the stress that results from such movement. Typical locations for vertical expansion joints include at intervals in long walls, interior corners, returns, and the jambs of large openings. See *Technical Notes 18* and *18A* for a thorough discussion of movements and detailing to address its effects, formulas for spacing of vertical expansion joints, and specific applications.

Details of typical expansion joints and their locations are shown in Figs. 14 and 15. Vertical expansion joints are usually $\frac{3}{8}$ " to $\frac{1}{2}$ " (9 mm to 13 mm) wide to match typical mortar joints and filled with a backer rod and sealant. Toothed expansion joints are difficult to construct and do not perform as well as straight expansion joints. For aesthetic reasons, consideration may be given to hiding vertical expansion joints in locations such as interior corners. It may be desirable to accentuate vertical expansion joints, making them attractive design elements, see Fig. 16. Joint reinforcement should not span vertical expansion joints.

Horizontal Expansion Joints

Cavity walls are successfully used as curtain walls in concrete and steel-frame buildings. In such instances,

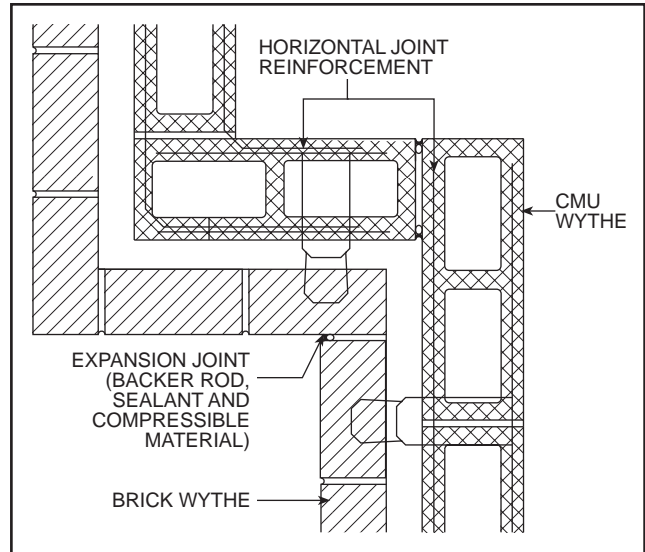

Vertical Expansion Joint at Interior Corner
FIG. 15

the inner wythe is usually supported by the building frame at each floor level. The outer wythe, often supported by shelf angles attached to the frame, is tied by metal ties to the inner wythe and the building frame. Care should be taken to ensure that the shelf angle is properly anchored and shimmed to prevent rotations and deflections that may induce high concentrated stresses in the masonry. Shelf angles should be designed so that total deflections are less than $\frac{1}{16}$ in. (1.6 mm). Shelf angles should be segmented to permit thermal expansion and contraction of the steel without damage to the wall. Spaces between segments of the shelf angle do not have to align with brick expansion joints. Continuous flashing should be installed above all shelf angles.

A horizontal expansion joint is formed by providing a minimum space of $\frac{1}{8}$ " (4 mm) below the shelf angle. This space is filled with a compressible material and sealed with an elastic sealant, typically of a color that

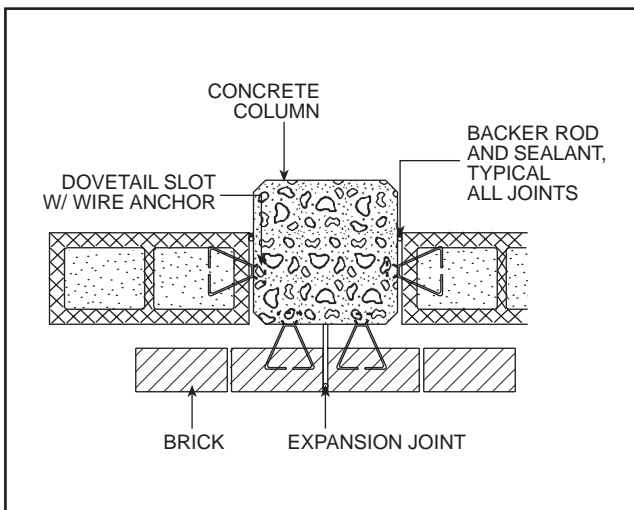

Vertical Expansion Joint
FIG. 14



Accentuated Vertical Expansion Joint
FIG. 16

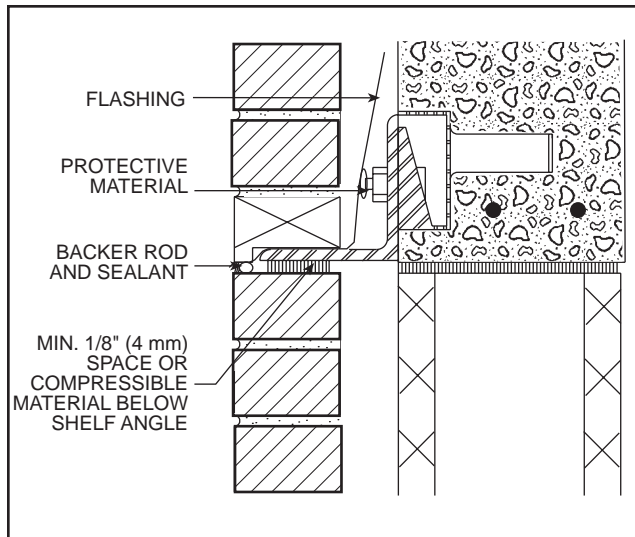

**Lipped Brick Detail
FIG. 17**

closely matches the mortar joint, see Fig. 8. In some instances, the width of the expansion joint below the shelf angle may be larger than is desirable. An alternate detail shown in Fig. 17 allows room for movement while providing a narrower joint.

Horizontal expansion joints may be eliminated by having the weight of the exterior wythe supported on the foundation. One alternative has both wythes of the cavity wall bypass the structural frame, with the weight supported on the foundation. The inner wythe is anchored to the structure with flexible anchors for lateral support. One method of such anchoring is shown in Fig. 18. Alternately, only the interior wythe can be supported on the structural frame. If this second support condition is used, it is imperative that adjustable ties be used between the wythes and that all components that penetrate or are attached to both wythes be detailed to permit differential movement.

ANCHORAGE AND TIES

Masonry walls used to enclose frame structures must be carefully designed and detailed to permit the transfer of loads applied to the wythes to the frame in a manner that accommodates relative movement. Frame structures are more flexible than masonry cavity walls and can undergo greater deflections. The frame and enclosing cavity wall also differ in their exposure and reaction to temperature and moisture conditions.

Anchors that provide lateral support to a wall should resist loads perpendicular to the plane of the wall, but should not transfer in-plane loads. This allows the vertical and horizontal movement of the brick in the plane of the wall while restricting its out-of-plane movement, and permits differential movement between the frame and the wall without cracking or distressing the masonry. Figures 18 through 20 show typical methods for anchoring masonry walls to columns and beams with metal anchors. Anchors must be detailed to accommodate construction

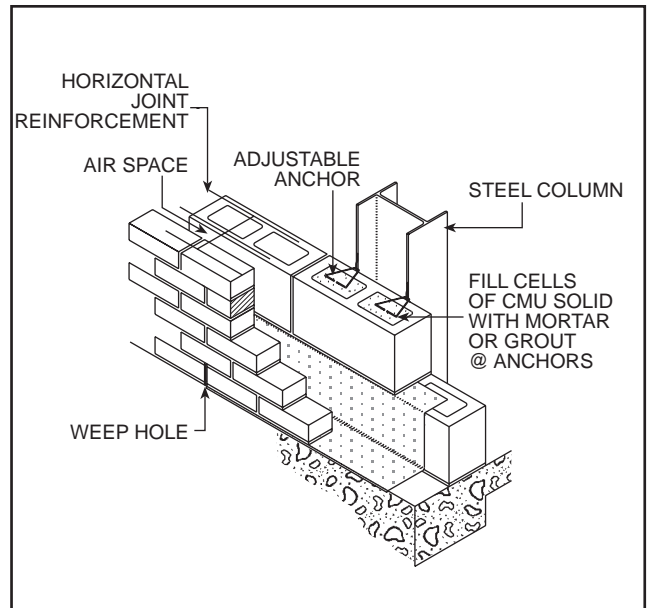

**Anchorage to Steel Column
(From *Masonry and Steel Detailing Handbook*,
W. Laska) (Fireproofing omitted for clarity)
FIG. 18**

tolerance differences and movement resulting from loads applied to the frame and floor elements. Anchors should not be located in the same bed joint as flashing.

A more complete discussion and examples of ties appropriate for connecting the wythes in cavity wall construction are given in *Technical Notes 21A*. As noted there, frequency and spacing of cavity wall ties depends on wire size and tie type. Table 1 contains such prescriptive requirements from *Building Code Requirements for Masonry Structures*, ACI 530/ASCE 5/TMS 402, [3] also known as the Masonry Standards Joint Committee (MSJC) Code.

In addition, ties must be located within 12 in. (305 mm) of openings larger than 16 in. (406 mm) in either direction. These ties are spaced at a maximum of 3 ft (0.91 m) on center around the perimeter. Ties should also be located within 12 in. (305 mm) of free edges of each wythe and at the horizontal or vertical spacing indicated.

**TABLE 1
Wall Tie Area and Spacing Requirements**

Tie Wire Size in. (mm)	Wall Area per Tie Number per ft ² (m ²)	Maximum Tie Spacing Horizontal by Vertical, in. (mm)
W1.7 (MW11) 0.125 (3.06)	2½ (0.25)	36 by 24 (914 by 610)
W2.8 (MW18) 0.188 (4.76)	4½ (0.42)	36 by 24 (914 by 610)
Adjustable, with 2 W2.8 (MW18) 1.88 (4.76) legs	1.77 (0.16)	16 by 16 (406 by 406)

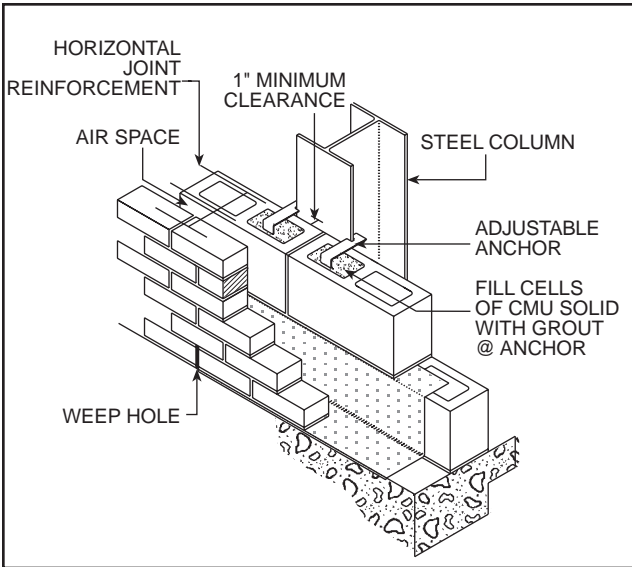

Anchorage to Steel Column
 (From *Masonry and Steel Detailing Handbook*,
 W. Laska) (Fireproofing omitted for clarity)
 FIG. 19

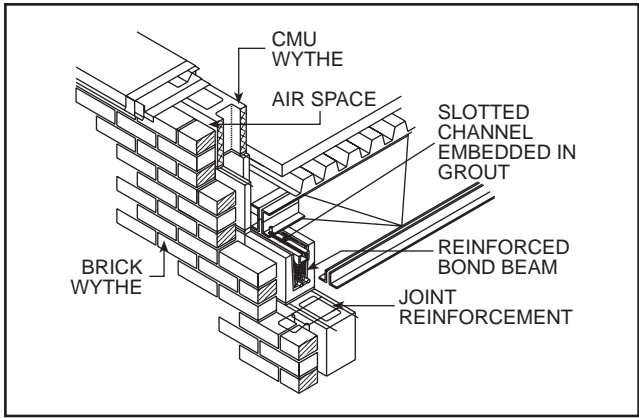

Steel Joist Bearing
 (From *Masonry and Steel Detailing Handbook*,
 W. Laska)
 FIG. 21

bolts should be hand-tightened or friction will prevent the necessary movement.

Minimum bearing requirements are established by the Steel Joist Institute and depend on the span and depth of the joist. Figure 21 illustrates a structural system using steel joists bearing on a masonry wall.

BEARING

Structural Steel

The coefficient of thermal expansion of steel is approximately twice that of brick masonry. When the temperature difference between the materials is large, and the steel is firmly anchored to or confined within the masonry, the potential for cracking the masonry wall increases. Masonry bond beams are usually placed in the interior wythe below the steel joists to distribute the load on the bearing wall. The common practice is to mechanically attach floor and roof joists to steel anchors embedded in the masonry. This detail can be improved by lubricating the bearing surfaces, or providing bearing pads with low coefficients of friction, and providing slotted holes in joist ends. Surrounding the joist end with a layer of building paper prior to grouting the bearing wall creates a slip joint, permitting movement. Anchor

Concrete Planks

Precast hollow-core concrete planks generally bear on the interior wythe of a cavity wall. The plank rests a minimum of 3 in. (75 mm) on a bearing pad that separates the plank from a concrete masonry bond beam below. Anchorage to the wall may be achieved with reinforcing steel (see Fig. 22) or, when lateral loads are small, planks may be solidly grouted to the wall. In either case, connections should be designed by a structural engineer.

Wood Floor Joists

Wood floor joists normally have a 3 in. (75 mm) fire cut end and bear only on the interior wythe of a cavity wall. The ends of the joist must not project into the cavity; they can form a ledge, which may create a moisture bridge across the cavity. Wood floor joists may also be fastened to metal joist hangers attached to a ledger bolted to the in-

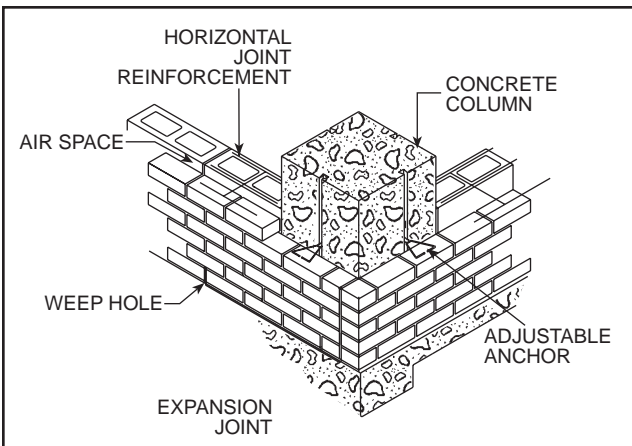

Anchorage to Concrete Column
 FIG. 20

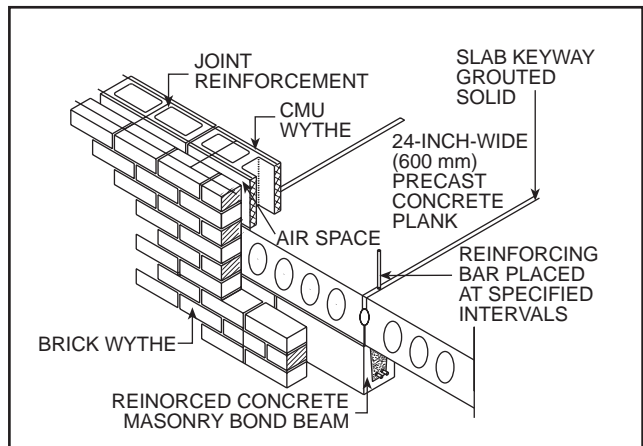

Steel reinforced Concrete Plank Bearing
 FIG. 22

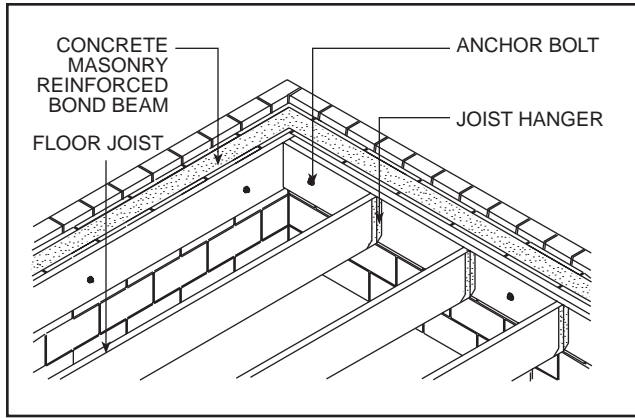

Wood Floor Joist Connection Detail
FIG. 23

ner wythe of the cavity wall, or joist hangers may be embedded in the inner wythe of the cavity wall. See Fig. 23.

Wood Roof Framing

Wood roof framing can be anchored to cavity walls by many methods, one of these is shown in Fig. 24. The detail illustrates a method in which the bearing plate is secured by anchor bolts grouted into the top of the cavity. The roof framing can then be attached to the bearing plate with strap anchors as shown. Anchor bolts holding roof plates should extend into the masonry a minimum of four bolt diameters or 2 in. (50 mm). Resistance to uplift of roof members may require longer bolt embedment or vertical reinforcement. After the wood plate is installed, the nut should be hand-tightened. Occasionally, a wind driven rain may cause a difference in pressure sufficient to drive water up over the top course of the exterior masonry wythe and into the cavity. This can be prevented by adding a frieze board that extends a few inches down from the top of the wall and is sealed against the masonry at the bottom.

BOND BREAKS

Foundations

Foundation movement may cause cracking in masonry walls rigidly attached to the foundation. Walls not bonded to the foundation tend to span the low points and thus reduce the potential for cracking. Figure 25 illustrates a typical foundation detail. In this case, the bond is broken

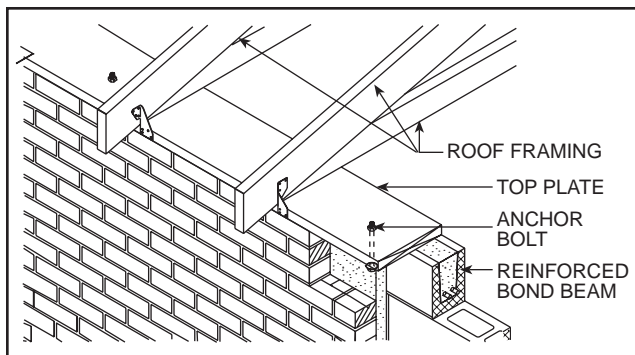

Wood Roof Framing Detail
FIG. 24

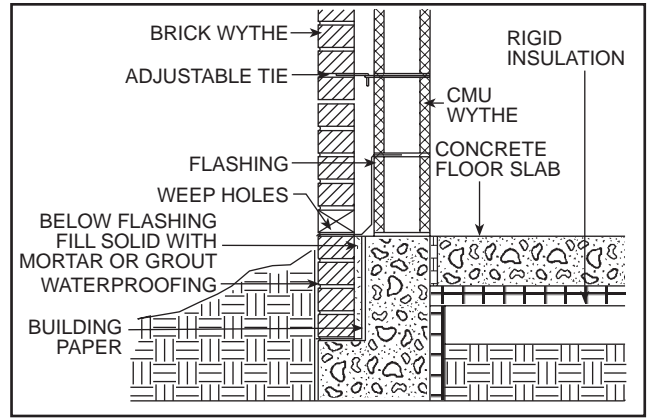

Foundation Detail
FIG. 25

between the base of the cavity wall and the top of the concrete foundation by building paper. The transfer of movement in the foundation to the wall is thus minimized. In many instances the brick wythe is separated from the foundation by flashing. Bond breaks also permit differential thermal and moisture movements without distress to either the brickwork or the concrete foundation.

In locations with high winds or seismic activity, it is necessary to anchor at least one wythe of the cavity wall to the foundation. This is typically achieved by bond between the mortar or grout, but may require the use of shear keys on reinforcing bars from the foundation into hollow masonry units or into a grouted cavity.

Concrete Slabs

Thermal strains or other movements are often blamed for cracking in masonry walls that is caused by the shrinkage or curling of concrete slabs that bear on the walls and are bonded to them. Curling of a concrete slab is caused by deflection of the slab when the forms are removed and response to dead and live loads. Unfortunately, this behavior of concrete is frequently overlooked by the designer in detailing the structure. Figure 26 illustrates a typical

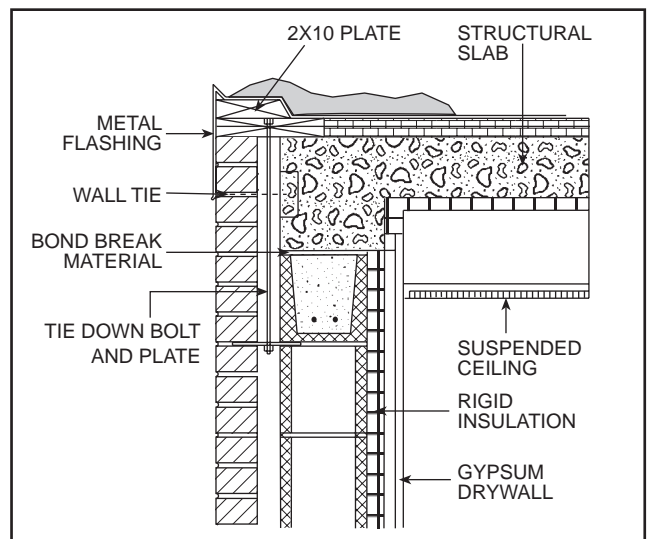

Concrete Roof Slab Detail
FIG. 26

detail that will relieve this condition. Installation of a bond break between the concrete slab and the concrete masonry permits the slab to have some freedom of movement with respect to the plane of the wall. The slab is thickened into a beam over the interior wythe to help stiffen the slab and minimize curling. The weight of the wall above the plate must be greater than the uplift force. Slab curling may also be reduced by placing diagonal reinforcement in the slab corners.

SEISMIC DETAILING

Masonry walls in buildings in locations with seismic activity must be designed to resist the lateral loads imposed by seismic events. The requirements are determined by the Seismic Design Category (SDC) into which the structure fits, as outlined in Minimum Design Loads for Buildings and Other Structures, ASCE 7 [13].

Seismic requirements for masonry walls are found in Section 1.13 of the 2002 MSJC Code, as well as in model building codes. Prescriptive amounts of horizontal and vertical reinforcement are required, based on Seismic Design Category and if the wall is part of the lateral force-resisting system. However, the requirements will not be discussed here as the focus of this *Technical Notes* is detailing. Such reinforcement must be placed with the restrictions for size, cover, and tolerances that are included in the building code.

SUMMARY

This *Technical Notes* has discussed and illustrated the general principles that are involved in the proper detailing of brick masonry cavity walls. It is not possible to cover all of potential conditions and variations in a single *Technical Notes*. However, the intent is to address the general principles and considerations for detailing.

The information and suggestions contained in this *Technical Notes* are based on the available data and the experience of the engineering staff of the Brick Industry Association. The information contained herein must be used in conjunction with good technical judgment and a basic understanding of the properties of brick masonry. Final decisions on the use of the information contained in this *Technical Notes* are not within the purview of the Brick Industry Association and must rest with the project architect, engineer and owner.

REFERENCES

1. Wallace, M.A., "Anatomy of a Cavity Wall", *Magazine of Masonry Construction*, Vol. 3, No. 7, July 1990, pp. 296-304.
2. Hoke, J.R., Editor, *Architectural Graphics Standards, Ninth Edition*, John Wiley & Sons Inc., New York, NY, 1994.
3. *Building Code Requirements for Masonry Structures and Commentary* (ACI 530/ASCE 5/TMS 402-02) and *Specification for Masonry Structures and Commentary* (ACI 530.1/ASCE 6/TMS 602-02), American Concrete Institute,

- Structural Engineering Institute of the American Society of Civil Engineers, and The Masonry Society, 2002.
4. Laska, W. and Ostrander, C., "Cavity Walls: A Case of High Performance", Masonry Advisory Council, Park Ridge, IL.
5. Krogstad, N., Weber, R., and Johnson, D., "Common Problems at the Interface Between Masonry Drainage Walls and Windows", American Society for Testing and Materials STP 1246, 1996, pp. 29-43.
6. Laska, W., "Connecting Precast Planks to Concrete Masonry Walls", *Magazine of Masonry Construction*, Vol. 4, No. 7, July 1991, pp. 250-251.
7. Hooker, K., "Corners in a Flash", *Magazine of Masonry Construction*, Vol. 4 No. 12, December 1991, p. 466.
8. Krogstad, N., Kozoil, R., and Weber, R., "Detailing Critical Interfaces Between Masonry Walls and Roofing Systems", Seventh Canadian Masonry Symposium, 1995, pp. 43-62.
9. Laska, W., "Detailing Shelf Angles", *Magazine of Masonry Construction*, Vol. 3, No. 7, January 1989, pp. 16-17.
10. Laska, W., *Masonry and Steel Detailing Handbook*, The Aberdeen Group, 1993
11. "Masonry: The Cavity Wall Controversy", Proceedings of the British Masonry Society, No. 5, May 1993.
12. Beall, C., *Masonry Design and Detailing: for Architects, Engineers and Contractors, Fourth Edition*, McGraw-Hill, 1997.
13. *Minimum Design Loads for Buildings and Other Structures* (ASCE 7), Structural Engineering Institute of the American Society of Civil Engineers, Reston, VA, 2002.
14. *Standard for Hurricane Resistant Residential Construction*, (SSTD 10), Southern Building Code Congress International, March 1999.
15. Subasic, C., "Seismic Reinforcement for Masonry", *Magazine of Masonry Construction*, Vol. 13, No. 4, April 2000, pp. 20-26.
16. Zinter, K., "Technical Guide-Selection and Use of Sealants", Bostik Inc., 1999.
17. *Uniform Building Code*, International Council of Building Officials, Council of Building Officials, Whittier, CA, 1997.
18. Catani, M.J., "Where Do You Need Joints?", *Magazine of Masonry Construction*, Vol. 1, No. 10, October 1988.